



| |
|-------------|
| Engineering |
| |
| Approved |
| |

**MODEL 47G-5A
 MAINTENANCE AND OVERHAUL INSTRUCTIONS
 TEMPORARY REVISION 47-15-2**

REFERENCE: Alert Service Bulletin 47-15-27

REASON: To improve integrity check of the throttle linkage assembly and graphically clarify proper safety wire installation of the throttle linkage assembly.

SAFETY WIRING OF THROTTLE CONTROL LINKAGE ASSEMBLY

Revise the Maintenance and Overhaul Instructions as follows and record this Temporary Revision on the "RECORD OF ACTIVE TEMPORARY REVISIONS" page:

- Section I, Daily Inspection, Page 1-45, Rev 0, 1 December 1971
 POWER PLANT AND ENGINE COMPARTMENT
 Revise Step 8 to address throttle linkage-carburetor security check:
 - 8. Inspect throttle, mixture, carburetor heat and fuel shut-off controls for general condition and security. Check controls for freedom of operation and full operating range. Check the throttle linkage-carburetor attachment for condition and security and for the presence and correct installation of the safety wire.

- Section V, Page 5-16, Rev 4, 1 October 1975
 Revise Figure 5-10 as shown on page 2 Temporary Revision:

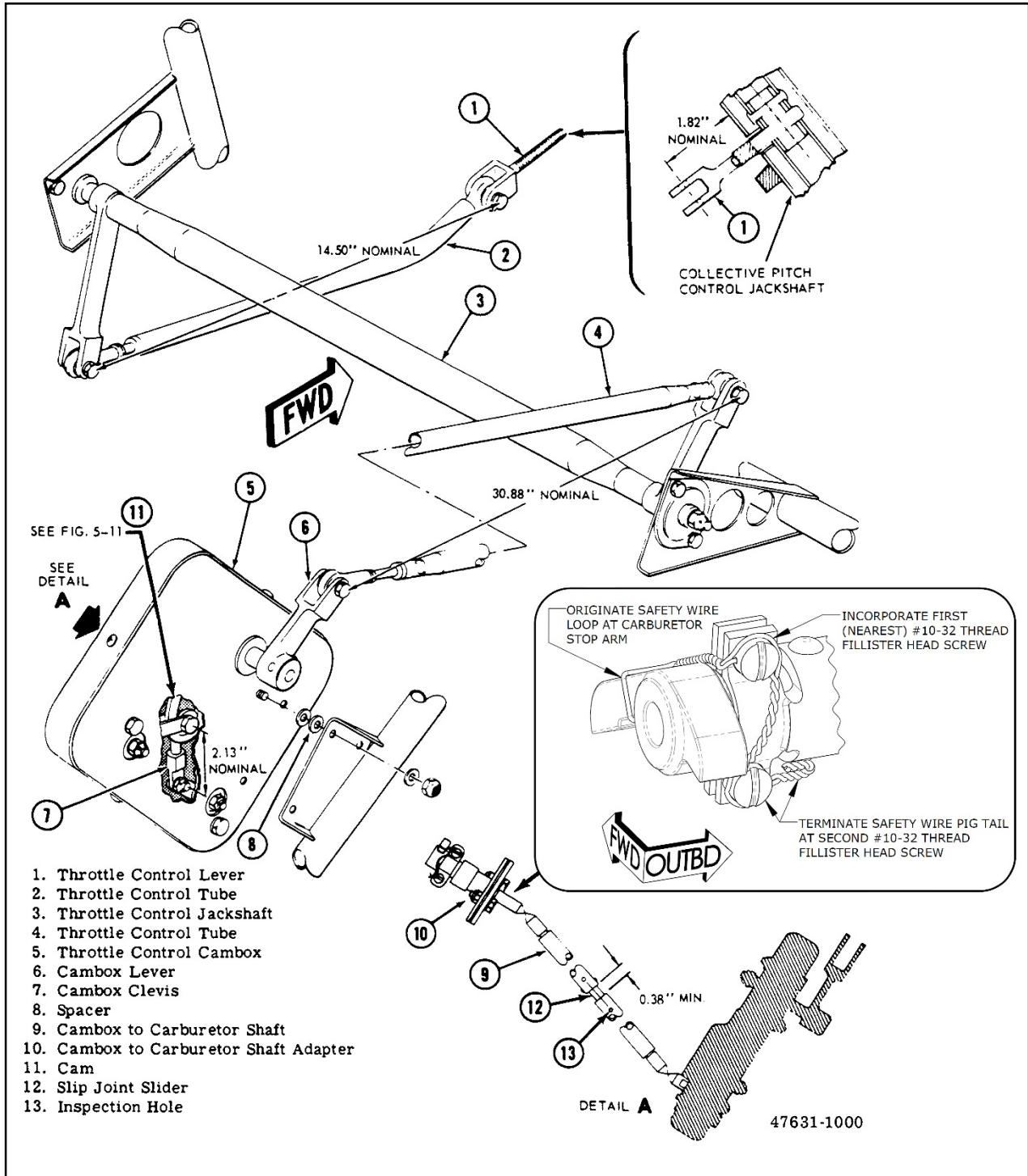

Figure 5-10. Throttle Control Installation (Sheet 1 of 2)