



Engineering
Approved

**MODEL 47G-3B-2A  
 MAINTENANCE AND OVERHAUL INSTRUCTIONS  
 TEMPORARY REVISION 47-15-2**

REFERENCE: Alert Service Bulletin 47-15-27

REASON: To improve integrity check of the throttle linkage assembly and graphically clarify proper safety wire installation of the throttle linkage assembly.

**SAFETY WIRING OF THROTTLE CONTROL LINKAGE ASSEMBLY**

Revise the Maintenance and Overhaul Instructions as follows and record this Temporary Revision on the "RECORD OF ACTIVE TEMPORARY REVISIONS" page:

- Section I, Daily Inspection, Page 1-57, Rev 0, 1 July 1974  
 POWER PLANT AND ENGINE COMPARTMENT  
 Revise Step 9 to address throttle linkage-carburetor security check:

9. Inspect throttle, waste gate, mixture, carburetor heat and fuel shut-off controls for general condition and security. Check controls for freedom of operation and full operating range. Check the throttle linkage-carburetor attachment for condition and security and for the presence and correct installation of the safety wire.

- Section V, Page 5-18, Rev 0, 1 July 1974  
 Revise Figure 5-11 as shown on page 2 of this Temporary Revision:

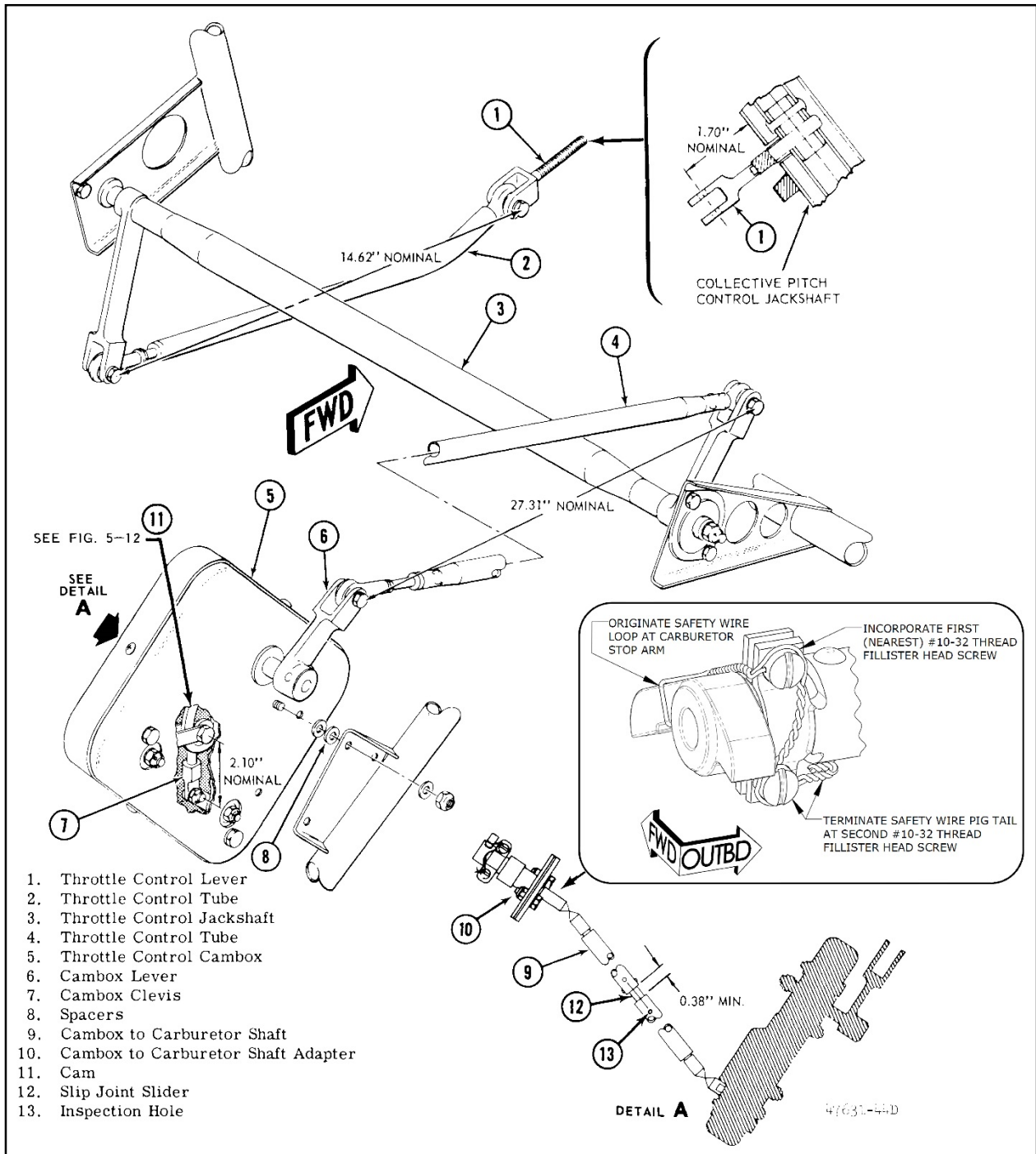

1. Throttle Control Lever
2. Throttle Control Tube
3. Throttle Control Jackshaft
4. Throttle Control Tube
5. Throttle Control Cambox
6. Cambox Lever
7. Cambox Clevis
8. Spacers
9. Cambox to Carburetor Shaft
10. Cambox to Carburetor Shaft Adapter
11. Cam
12. Slip Joint Slider
13. Inspection Hole